

SABA

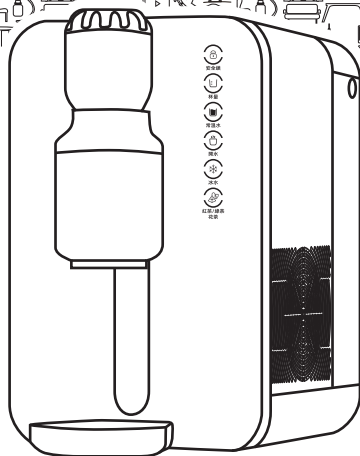
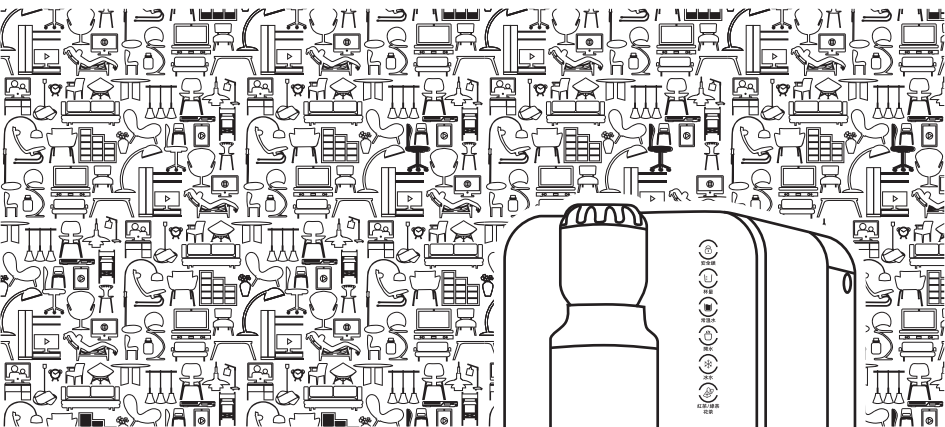

> 使用說明書

Instruction Manual

冰溫熱即熱式濾淨開飲機(家庭用)

Water dispenser

SA-HQ10

Read this booklet thoroughly before using and save it for future reference

目錄

免責聲明	-----1
緊急處理方法&警告	-----1
安全注意事項	-----2
各部位名稱	-----3
使用注意事項	-----4
操作介面	-----4
操作顯示功能說明	-----5
清潔與存放	-----6
簡易故障排除	-----6
規格	-----7
限用物質含有情況標示	----7

免責聲明

本手冊經仔細檢查及校對，但仍不排除文字拼寫及技術錯誤之可能，若因錯誤導致與實機不符時，以實機為準，此種錯誤或疏漏不能當呈堂的依據，其將於新版予以修正。

本手冊之全部內容，本公司享有隨時修改之權力，且不另行通知。

緊急處理方法 & 警告

當發生異常或有燒焦味時，應立即停止使用，並與本公司服務專線聯絡或就近經銷商洽詢，若在異常狀態下繼續使用易發生火災之危險。

為了避免火災或是電擊的危險，請勿讓本機暴露於雨中或濕氣中。

電源請確實插牢於電源插座內，以免因未插牢而引起插頭產生高熱，而造成意外。

電源線或電源底座若損壞時，請速與本公司服務專線聯絡或就近經銷商洽詢。

安全注意事項

使用飲水機前請詳細閱讀本明書並正確使用飲水機

注意：避免觸電，請在清洗或檢查機器前切斷電源。

警告：

本機器只能使用固定且合適的插座 連接電源，不能使用接線板，以免因接線板過電量不夠導致引起火災。

孩童應受監護，以確保孩童不嬉玩電器。

本電器不預期供生理、感知、心智能力、經驗或知識不足之使用者(包含孩童)使用，除非在對其負有安全責任的人員之監護或指導下安全使用。

1. 本機只適合室內使用，如家居、店舖、辦公室、酒店、旅館及餐廳等類型環境。
2. 本產品為塑膠外殼，電源線採用三極安全插頭(插頭處有標誌接地符號)，使用時插頭必 插入有接地線的三極安全插座上，禁止用力拉扯電源線。
3. 如果電源軟線損壞，為了避免危險，必須由制造商、其維修部或類似部門的專業人員更換。
4. 使用前務必查看線路是否符合銘牌中各參數的電壓、功率標示，防止線路過載。
5. 初次使用本產品或長期不使用後重新使用本產品，首箱水不建議飲用。
6. 任何時候，請務必不要接觸機器的出水口，以免導致燙傷。
7. 機器在工作時不得更換水。
8. 避免機器傾倒，請將機器固定於水平的台面上，如有需要，可與客服聯繫。
9. 本產品只適用於以符合國家標準要求的蒸餾水及其它可直接飲用的純淨水為原水，嚴禁倒入牛奶、飲料與其它液體加熱。
10. 因不正當用途、錯誤使用、換作不當和擅自修理拆卸本產品，本公司概不負任何責任，因此而導致的損壞也不在維修範圍內。
11. 本產品嚴禁幼兒操作，以免熱水燙傷，在有幼兒的場所使用，建 啟用童鎖功能。
12. 本產品應遠離高溫，放置在陰涼、乾燥、通風的環境中，禁止有戶外陽光直射或有水噴濺的地方使用，並遠離易燃及易爆物品。
13. 內部加熱系統在加熱時會產生短暫的噴汽現象，是因為水充分沸騰而產生的，屬於正常現象。
14. 飲水機請平穩放置於平面上，四周與牆壁必需有大於15厘米以上間隔，飲水機過熱可能使機器的性能降低而引起火災。
15. 本機器建議使用環境溫度為4°C~40°C當使用環境低於10°C，請關掉製冷開關，以免發生冰堵。
16. 當機器進行清潔或維修前，應先關掉電源開關，然後拔掉電源插頭，不要將機器放入水中清洗或用氣體、化學藥劑來擦洗機身和水箱，請用乾淨的抹布清潔機身和水。
17. 高溫水為燒開的水切勿使用不耐溫容器裝盛。
18. 當底部接水盤滿時 只需用手將接水盤的水倒掉，然後安放回原處即可。
19. 為了您的飲水健康，機器注意定期清洗消毒。
20. 機器應放置在兒童及寵物無法觸及的地方。
21. 倘若發生故障，應立即拔掉電源插頭，勿切將有缺陷的機器置於工作狀態。
22. 切勿自行拆卸、改裝機器或在機器上放置重物，以免損壞機器。
23. 為避免窒息的危險，請將塑膠袋遠離嬰兒和兒童。
24. 本機器建議在海拔不高於2500米的地區使用。

各部位名稱

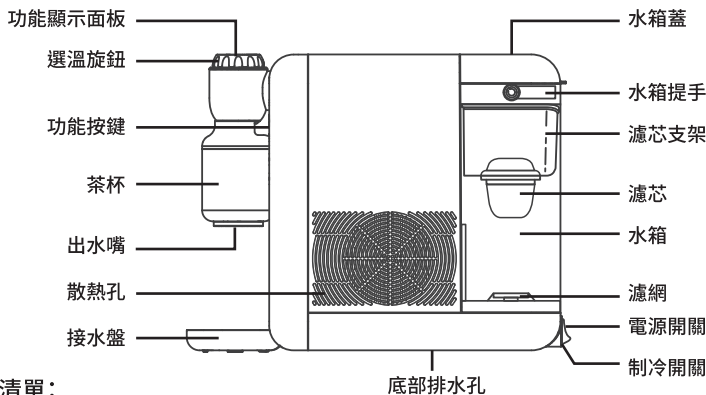

裝箱清單：

主機x1台、水箱x1、接水盤x1個、茶杯x1個、濾芯x1個、濾芯支架x1個、說明書x1本

使用注意事項

- 用清水沖洗水箱內外壁；
- 裝入常溫純淨水至最高水位線；
- 打開機器後側電源開關；
- 輕觸安全鎖鍵解鎖，再轉動選溫旋鈕選擇常溫，最後輕觸功能顯示面板上的出水鍵，進行取水。 注意：為避免發熱體乾燒，首次使用請先出一杯常溫水。

注意事項

- 水箱的清洗與盛裝請使用常溫水；
- 水箱為食品級塑膠，請勿使用50度以上的水或蒸餾水箱，避免變形；
- 機器出廠前都經過通水及功能檢測，出水嘴如有餘水屬正常現象；

冰水功能激活

- 水箱裝入1L以上的常溫純淨水，出水嘴下方放置接水容器；
- 打開機器後側電源開關及制冷開關；
- 輕觸安全鎖鍵解鎖，再長按冰水鍵，直至蜂鳴器響，首次冰水程序啟動，激活完成後蜂鳴器響，再次輕觸出水按鍵，可正常出水，程序成功。（新機器激活期間，冰膽處於儲水狀態，出水口可能沒水流出，屬於正常現象；有水流出，則冰膽已經存滿水，已經完成冰水功能程序）
- 程序成功後，顯示面板制冷工作指示燈閃爍，完成後指示燈熄滅。
(冰水模式下小於0°C 制冷工作指示燈恆亮)

三步獲得一杯滿意的水

- 打開電源開關（使用冰水功能時，同時打開制冷開關），輕觸童鎖解鎖。
- 轉動旋鈕選擇溫度或者輕觸快捷水溫按鍵。
- 輕觸功能顯示面板的出水/停止鍵即可獲得一杯滿意的水，再次輕觸出水/停止鍵可中斷出水
杯量：小杯150mL、中杯250mL、大杯350mL、不定量（不顯示杯量）

操作介面

功能按鍵



安全鎖



杯量



常溫水



開水



冰水



紅茶/綠茶
花茶

功能顯示面板

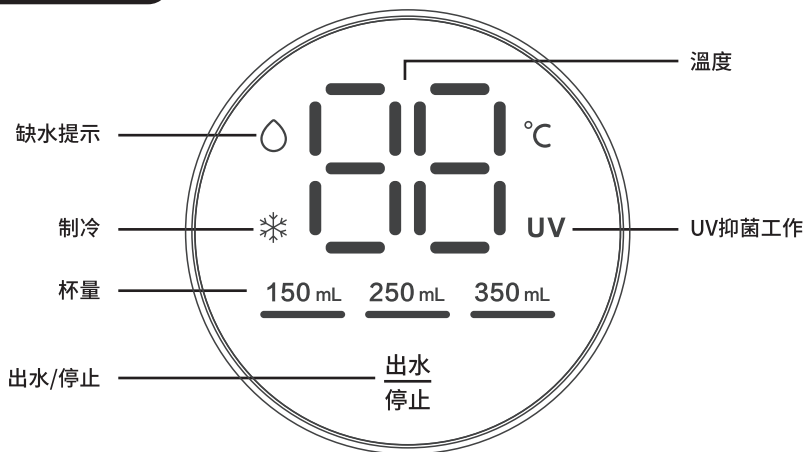

操作顯示功能說明

功能選擇與出水

有效觸摸童鎖鍵解鎖→旋轉選溫旋鈕或在功能選取面板選取水溫→選取水量→按功能顯示面板的出水鍵，水機開始工作出水。

功能說明



安全鎖

1、安全鎖 鍵

- (1) 出廠設置為自動上鎖，輕觸解鎖，再次輕觸可上鎖，整機默認時間內無操作自動上鎖。
- (2) 按“安全鎖”，蜂鳴器發出聲響後，關閉此功能(可手動上鎖或解鎖)；再次按“安全鎖”，蜂鳴器發出聲響後，開啟自動此功能。

操作顯示功能說明

出水 停止

2、出水鍵

在解鎖狀態下，旋轉選溫旋鈕或觸按杯量鍵，選定水溫以及水量，再輕觸出水鍵，機器按選定的水溫及水量進行出水。機器在出水狀態下，再按取水鍵，機器停止出水。



杯量

3、杯量鍵

在解鎖狀態下，觸按杯量鍵，選取出水量：150mL→250mL→350mL→不定量……循環選擇。



常溫水

4、常溫水 鍵

在解鎖狀態下，按“常溫水”，此時顯示幕顯示00，旋轉選溫旋鈕或按其他水溫選取鍵可改變選取的水溫。



開水

5、開水鍵

在解鎖狀態下，按開水鍵，即選取常開水功能。此時：顯示屏顯示HI，旋轉選溫旋鈕或按其它水溫選取鍵可改變選取的水溫。



冰水

6、冰水鍵

在解鎖狀態下，按冰水鍵，即選取冰水功能。此時：顯示屏顯示CO，旋轉選溫旋鈕或按其它水溫選取鍵可改變選取的水溫。



紅茶 / 綠茶
花茶

7、紅茶/綠茶/花茶 鍵

在解鎖狀態下，按紅茶/綠茶/花茶按鍵，即可依次選擇功能，再輕觸出水鍵即可一鍵泡茶。裝好茶杯，選擇行程，杯量顯示250ml。按出水鍵出水，第一次水140ml將茶葉浸泡，顯示幕顯示倒數計時60秒再次注水110ml後自動出水。

紅茶-亮紅燈，屏幕顯示HI / 綠茶-亮綠燈，屏幕顯示95度 / 花茶-亮藍燈屏幕顯示90度

注意

1. 泡茶檔出水分為兩次注水，第一次注水將茶葉浸泡，倒計時結束後，再次注水並自動出水。
2. 泡茶檔水量不可調，請使用合適的器具在茶倉出水口盛載，小心高溫燙手。
3. 泡茶功能運行時，可按出水鍵進行暫停，再次按出水鍵繼續運行。泡茶時不可退出，需等待完成整個泡茶步驟再享用。
4. 當茶杯已有水時，泡茶第一段注水可能會導致茶倉出水，請用戶按出水鍵暫停注水。待茶杯水自動排空後，再重新通電啟動泡茶功能。
5. 當茶杯出水時，因使用虹吸原理出水，其間無法停止，請用戶使用合適的器具盛載，小心高溫燙手。
6. 不使用此功能時，請將茶杯取下。

8、選溫旋鈕

旋轉選溫旋鈕水溫：順時針轉動，溫度調高；逆時針轉動，溫度調低；



9、制冷指示

選溫旋鈕上的冰水顯示圖標為制冷指示，運行時閃爍，達到溫度或不運行時熄滅。



10、缺水提示

當系統檢測到水位達到報警水位時，即視為缺水並進行保護。進入缺水保護狀態，水泵與加熱體不工作，顯示幕功能鍵燈號全滅。

清潔與存放

1、外部清潔

拔下電源插頭，確保機器斷電；待機器完全冷卻後用擰乾的抹布對表面進行擦拭清潔；水箱用清水清洗，清洗後擦乾。

注意：請勿使用50°C以上的水，嚴禁煮沸水箱；

注意：機器除水箱外，機身應避免用水直接沖洗，並且任何時候不得將整機浸入水中。

2、內部清潔(第一次使用或長時間停用後重新使用)

(1)水箱加入2L常溫水，出水口放置一個2L以上接水容器。

(2)安全鎖模式下，長按“杯量”鍵，此時蜂鳴器發出聲響，進入自潔程序。

(3)計時99秒，依此顯示進行清洗進度。

3、清潔除垢

(1)在水箱內加入2L以上的水並添加適量的除垢劑後，啟動清除餘水功能，並在出水口放置一個容量在2L以上的接水容器，出水過程中按出水鍵切換沖洗管路。

(2)將水箱裝水至最高水位線後，啟動自清潔功能(請參考上述內部清潔功能內容說明)

注意：

機器在使用30天以內若出現白色漂浮物，建議每10天清洗一次；

機器在使用時間超過30天時出現白色漂浮物，建議每30天清洗一次；

若首次使用飲水機就出現白色漂浮物，表示水質硬度等級較高，建議更換水源或使用純淨水；

如果計劃機器長期不使用，請通過機器底部手動排水口和清除餘水功能將機器內餘水排空，再次使用時，請按首次使用的步驟清洗。

簡易故障排除

缺水警報：當機器檢測到缺水時，進入缺水保護狀態，水泵停止並且不再加熱，缺水指示燈閃爍，蜂鳴器響聲提示。按出水鍵解除缺水保護，缺水指示燈熄滅，再次按出水鍵則可以正常工作出水。

故障現象	原因分析	處理方法
機器不通電	1、電源未接通 2、內部連接線鬆脫 3、電源開關沒有閉合	1、檢查電源插頭是否插好 2、請聯系售後服務人員 3、將機器後面電源開關閉合
按鍵不出水	1、機器進入童鎖狀態 2、電路控制故障	1、檢查童鎖按鍵燈是否亮並進行解鎖 2、請聯系售後服務人員
沒有水流出或水流太小	機器內水垢或雜質太多堵住水口	請參考清潔保養說明
熱水溫度不夠高	1、水垢太多或電路控制功能異常 2、電源電壓異常	1、請參考清潔保養說明 2、請專業人員檢查電源電壓 3、請聯系售後服務人員
故障代碼E1	發熱體超溫	1、檢查機器常溫水出水是否正常 2、請聯系售後服務人員
故障代碼E2	進水溫度過高	水箱請加入5-38°C純淨水
故障代碼E3	出水溫度傳感器故障	請聯系售後服務人員
故障代碼E4	進水溫度傳感器故障	
故障代碼E5	熱水泵故障	請聯系售後服務人員
故障代碼E6	冷水泵故障	
機器不制冷	1、制冷開關沒有閉合 2、新機器未進行冰冰激活功能	1、將機器後面制冷開關閉合 2、進行冰冰激活功能操作

規格

額定電壓/頻率: 110V~/60Hz

總額定消耗電功率:1500W

水箱容量:3.5L

商品原產地: 中國

限用物質含有情況標示

設備名稱：冰溫熱即熱式濾淨開飲機

型號：BZ-WTC010/020/030/SA-HQ10

單元 Unit	限用物質及其化學符號					
	鉛 Lead (Pb)	汞 Mercury (Hg)	鎘 Cadmium (Cd)	六價鉻 Hexavalent chromium (Cr ⁺⁶)	多溴聯苯 Polybrominated biphenyls (PBB)	多溴二苯醚 Polybrominated diphenyl ethers (PBDE)
電控版組件	—	○	○	○	○	○
面板及其組件	○	○	○	○	○	○
後蓋及連接線	○	○	○	○	○	○
電源線及連接線	○	○	○	○	○	○
包裝印刷組件	○	○	○	○	○	○

備考1. “超出0.1 wt %”及“超出0.01 wt %”係指限用物質之百分比含量超出百分比含量基準值。

備考2. “○”係指該項限用物質之百分比含量未超出百分比含量基準值。

備考3. “—”係指該項限用物質為排除項目。



保固 使用說明



使用教學



數位保固卡



線上客服



數位說明書

服務/保固/教學

就在  @wonder.tw 解決你的困擾

Contents

Safety Precautions	1-2
Product specifications	2
Name of each part	2
Precautions for use	3
Operating interface	4
Operating display function description	4-5
Cleaning and storage	6-7
Troubleshooting	7

Safety Precautions

Please read this manual thoroughly before using the water dispenser and use the water dispenser correctly. Note: to avoid electric shocks, please disconnect the power before cleaning or inspecting the machine.

Warning:

Only fixed and suitable outlets can be used to connect the power of this machine; extension cords must not be used to prevent the extension cord from having insufficient power and causing fire.

Children should be supervised to make sure that they do not play with electrical appliances.

This electrical appliance is not intended for use by users (including children) with reduced physical, sensory, mental capabilities, experience or knowledge, unless used safely under the supervision or guidance of the person responsible for their safety.

1. This machine is suitable for indoor use only; environments such as homes, stores, offices, hotels, bed & breakfast places and restaurants.

2. This product has a plastic case and its power cable has a three-pole safety plug (there is a grounding symbol by the plug); make sure to insert the power plug into a three-pole safety outlet with grounding when using and do not tug on the power cable forcefully.

3. If the power cable is damaged, in order to avoid danger, it should be replaced by professionals from the manufacturer, its maintenance department or similar departments.

4. Make sure to check whether or not the circuit complies with the voltage and power labels of the various parameters on the nameplate before use to prevent the circuit from overloading.

5. It is not recommended to drink from the first tank of water when using this product for the first time or using this product again after not using it for a long period of time.

6. Do not touch the water outlet of the machine at any time to prevent scalding.

7. Do not replace the water while the machine is operating.

8. Prevent the machine from tilting and fix the machine on a horizontal surface; contact customer service, if needed.

9. This product is only suitable for use with distilled water that meets national standard requirements and other pure water that can be drunk directly such as raw water; it is strictly prohibited to fill it with milk, beverages or other liquids for heating.

10. Our company is not responsible for any improper use, wrong usage, improper replacement and unauthorized repairing and dismantling of the product; therefore, the damages that resulted from these will not be covered by the warranty.

11. It is strictly prohibited for children to operate this product to prevent scalding from hot water; it is recommended to enable the child lock function when using this product at locations with children.

12. This product should be kept away from high temperatures and placed in cool, dry and ventilated environments; it is prohibited to use the product outdoors at places with direct sunlight exposure or splashing water, and keep the product away from flammable and explosive objects.

13. The internal heating system will produce short bursts of steam when eating, which are generated by the boiling water; this is normal

14. Please place the water dispenser steadily on a flat surface, and keep it at least 15cm away from surrounding walls. If the water dispenser overheats, it may cause reduced performance and result in a fire.

15. The recommended usage ambient temperature of this machine is 4°C~40°C; when using the machine in environments under 10°C, please turn off the refrigeration switch to prevent ice blockage.

16. The power switch should be switched off and the power plug unplugged from the outlet before cleaning or maintaining; do not clean the machine by submerging it under water or wiping the body of the machine and the water tank with gases or chemicals. Please clean the body of the machine and the water tank with a clean cloth.

17. The high temperature water is boiled water; do not use temperature-intolerant containers with the high temperature water.

18. When the water tray at the bottom is full, simply empty the tray with your hands and then return the water tray to its original location.

19. For healthy drinking, make sure to clean and disinfect the machine regularly.

20. The machine should be kept out of reach of children and pets.

21. If there are malfunctions, the power plug should be unplugged immediately; do not keep using the malfunctioning machine.

22. Do not disassemble or modify the machine by yourself, or place heavy objects on the machine in order to avoid damaging the machine.

23. To avoid the danger of suffocation, please keep the plastic bags away from infants and children.

24. It is recommended to use this machine at areas with altitudes no higher than 2,500 meters.

Product specifications

Rated voltage / frequency: 110V~ / 60Hz

Total rated power consumption: 1500W

Country of Origin : China

Name of each part

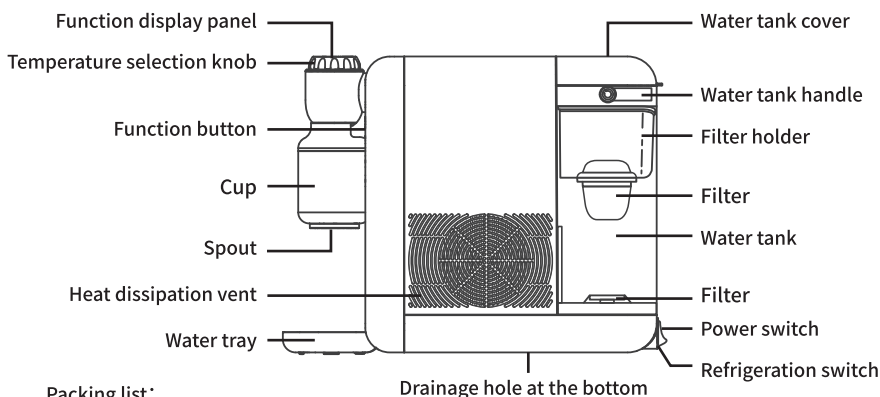

Packing list:

Host unit x1, water tank x1, water tray x1, cup x1, filter x1, filter holder x1, manual x1

Precautions for use

- Rinse the inner and outer walls of the water tank with clean water;
- Fill the normal temperature pure water to the highest water level line;
- Turn on the power switch behind the machine;
- Touch the safety lock key gently to unlock the machine, then rotate the temperature selection knob to normal temperature; finally, touch the dispense water key on the display panel gently to dispense water. Note: to prevent the heating chamber from dry burning, please dispense a cup of normal temperature water first when using the machine for the first time.

Notes

- Please use normal temperature water to clean and fill the water tank;
- The water tank is made of food-grade plastic; do not use water 50 degrees or above or steam and boil the water tank to avoid deformation;
- The machine has passed water and function tests before it is shipped from the factory; therefore, it is normal if there is residual water at the spout;

Enabling ice water function

- Fill the water tank with 1L or more of normal temperature pure water and place a water container below the spout;
- Turn on the power switch and refrigeration switch behind the machine;
- Touch the safety lock key gently to unlock the machine, then long-press the ice water key until the buzzer sounds. The buzzer will sound after the ice water procedure is enabled and activated for the first time, then touch the water dispensing key gently again; if water dispenses normally, the procedure is successful. (While the new machine is enabling, the ice-lining component is in a water storing state, and there may be no water coming out of the spout; this is normal. If water comes out, it means that the ice-lining component is full of water, and the ice water function procedure has completed successfully) •After the procedure ends successfully, the refrigeration task indicator on the display panel starts flashing; the indicator will go off when completed.

(When it is under 0°C in ice water mode, the refrigeration task indicator will remain constantly on)

Three steps to get a glass of satisfying water

- Turn on the power switch (also turn on the refrigeration switch when using the ice water function) and touch the child lock gently to unlock the machine.
- Rotate the knob to select the temperature or touch the water temperature shortcut keys gently.
- Touch the water dispensing/stop key on the function display panel gently to get a glass of satisfying water; touch the water dispensing/stop key gently again to stop dispensing water. Cup size: Small cup 150mL, medium cup 250mL, large cup 350mL, no specific amount (cup size not displayed)

Operating interface

Function button



安全鎖

Safety lock



杯量

Cup size



常溫水

Normal temperature water



開水

Boiled water



冰水

Ice water



紅茶/綠茶
花茶

Black tea/
green tea/
scented tea

Function display panel

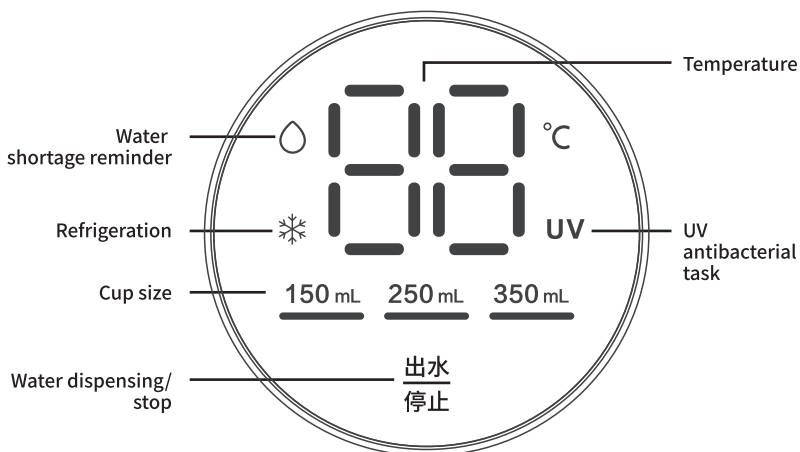

Operating display function description

Function selection and water dispensing

Touch the child lock key effectively to unlock the machine, rotate the temperature selection knob or choose the water temperature from the function selection panel, select the water amount, press the water dispense button on the function display panel and the water dispenser will start working and dispense water.

Function description



1. Safety lock key

(1) The default factory setting is set to lock automatically; touch gently to unlock the machine, then touch it gently again to lock the machine. Automatic locking cannot be operated within the default time of the machine.

(2) Press the "safety lock" and wait for the buzzer to sound to disable this function (able to lock or unlock manually);

Safety lock, press the "safety lock" again and wait for the buzzer to sound to enable this function automatically.

出水
停止

2. Water dispensing key

Under unlocked status, rotate the temperature selection knob or touch the cup size key gently to select the water temperature and volume, then touch the water dispensing key gently and the machine will dispense water according to the water temperature and volume selected. Pressing the water dispensing key again while the machine is dispensing water will stop the machine from dispensing water.



3. Cup size key

Under unlocked status, touch the cup size key gently to select the water dispensing volume: 150mL, 250mL, 350mL, no specific volume... Cycle selection.



4. Normal temperature water key

Under unlocked status, press "normal temperature water" and the display screen will show 00 at this time; rotate the temperature selection knob or press other water temperature selection keys to change the selected water temperature.



5. Boiling water key

Under unlocked status, press the boiling water key to select the always boil water function. At this time: The display screen shows 99°C; rotate the temperature selection knob or press other water temperature selection keys to change the selected water temperature.



6. Ice water key

Under unlocked status, press the ice water key to select the ice water function. At this time: The display screen will show CO; rotate the temperature selection knob or press other water temperature selection keys to change the selected water temperature.

7. Temperature selection knob

Water temperature when the temperature selection knob is rotated: Rotate clockwise to increase the temperature; rotate counter-clockwise to decrease the temperature.



8. Refrigeration indicator

The ice water display icon on the temperature selection knob is the refrigeration indicator; it flashes while operating and will go off when the desired temperature is reached or when not operating.



9. Water shortage indicator

When the system detects that the water level reached an alarming water level, it will consider it as having water shortage and will perform protection. It will enter water shortage protection status; the water pump and heating chamber will stop operating and all the function key lights on the display screen will go off.

10 Black tea/green tea/scented tea key

Under unlocked status, press the black tea/green tea/scented tea key to select the functions sequentially, then touch the water dispensing key gently to make tea with the press of a button.

Put the cup in place, select the itinerary and the cup size shows 250ml. Press the water dispensing key to dispense water; the first 140ml of water will soak the tea leaves, and the display screen will count down 60 seconds before the water is dispensed again automatically for 110ml.

Black tea - the red light turns on and the screen shows HI / Green tea - the green light turns on, and the screen shows 95 degrees / Scented tea - the blue light turns on and the screen shows 90 degrees.



Note:

1. Water is dispensed two times for the tea-making gear; the first water dispensing will soak the tea leaves and when the countdown ends, water will be dispensed again automatically.
2. The water volume for the tea-making gear is not adjustable; please use an appropriate container in the tea holder water outlet and be careful not to let the hot water scald your hands.
3. While the tea-making function is operating, you can press the water dispensing key to pause the process, then press the water dispensing key again to continue the process. The process cannot be exited while making tea; you must wait until the entire tea making process is completed before you can enjoy the tea.
4. When there already is water in the cup, the first stage of water dispensing may cause water to spill from the tea holder; users must press the water dispensing key to suspend water dispensing. Wait for the water in the cup is drained automatically, then reconnect the power and restart the tea-making function.
5. When water is being dispensed into the cup, since water is dispensed using the siphon principle, it cannot be stopped during the process; users must use an appropriate container and beware not to get scalded from the hot temperature.
6. Please remove the cup when not using this function.

Cleaning and storage

1. Cleaning the exterior

Unplug the power plug and make sure power is disconnected from the machine; wait until the machine has cooled off completely, then wipe and clean the surface with a wrung-out cloth; Clean the water tank with clean water, then wipe it dry after cleaning.

Note: do not use water 50°C or above and it is strictly prohibited to steam or boil the water tank; Note: except for the water tank, avoid rinsing the body of the machine with water directly and do not submerge the entire machine under water at any time.

2. Internal cleaning (When using the machine for the first time or using it again after not using it for a long period of time)

(1) Add 2L of normal temperature water into the water tank, and place a container that can hold more than 2L of water by the spout.

(2) Under safety lock mode, long-press the "Cup size" key and the buzzer will sound at this time and the machine will enter the self-cleaning process.

(3) Counts down for 99 seconds and uses this to show the cleaning progress.

3. Cleaning dirt

(1) Add 2L or more of water into the water tank and add an appropriate amount of descaler, then start the residual water clearing function and place a container that can hold 2L or more of water by the spout; press the water dispensing button during the water dispensing process to switch and flush the pipelines.

(2) Fill the water tank with water to the highest water level line, then start the self-cleaning function (please refer to the descriptions of the internal cleaning function content above)

Note:

If white floating objects appear within 30 days of using the machine, it is recommended to clean the machine once every 10 days;

If white floating objects appeared after more than 30 days of using the machine, it is recommended to clean the machine once every 30days;

If white floating objects appeared when the machine was used for the first time, it means that the water quality has a higher hardness level; it is recommended to change the water source or use pure water;

If you do not plan to use the machine for a long time, please drain the remaining water in the machine through the manual drain outlet at the bottom of the machine and the clear residual water function; when you are ready to use the machine again, please clean it by following the steps for using the machine for the first time.

Troubleshooting

Water shortage alarm: when the machine detects that there is water shortage, it will enter the water shortage protection status; the water pump will stop and water will no longer be heated, the water shortage indicator will flash and the buzzer will sound. Press the water dispensing key to release the water shortage protection; the water shortage indicator will go off, then press the water dispensing key again to allow the machine to work normally and dispense water again.

Fault phenomenon	Cause analysis	Handling method
Machine has no power	1.Power source not connected 2.Internal connection wires have become loose 3.Power switch not turned on	1.Check whether or not the power plug is inserted properly 2.Please contact after-sales service personnel 3.Turn on the power switch behind the machine
No water is dispensed when the key is pressed	1.The machine is in child lock status 2.The circuit controls have failed	1.Check whether or not the child lock key light is on and unlock it 2.Please contact after-sales service personnel
No water comes out or the water flow is small	There are too much scales or impurities inside the machine that are blocking the water outlet	Please refer to the descriptions for cleaning and maintenance
The temperature of the hot water is not hot enough	1.There are too much scales or the circuit control functions are abnormal 2.The power voltage is abnormal	1.Please refer to the descriptions for cleaning and maintenance 2.Please have professionals check the power voltage 3.Please contact after-sales service personnel
Fault code E1	Heating chamber overheated	1.Check whether or not the machine's dispensing of normal temperature water is normal 2.Please contact after-sales service personnel
Fault code E2	The inlet water temperature is too high	Please add pure water between 5-38°C into the water tank
Fault code E3	Water outlet temperature sensor failure	Please add pure water between 5-38°C into the water tank
Fault code E4	Water inlet temperature sensor failure	Please contact after-sales service personnel
Fault code E5	Hot water pump failure	
Fault code E6	Cold water pump failure	
Machine does not refrigerate	1. The refrigeration switch is not on 2. The ice water enabling function was not performed for the new machine	1. Turn on the refrigeration switch behind the machine 2. Perform the ice water enabling function operation

非常感謝您：

承蒙惠購本產品，本公司除表達最高謝意外，並將本著一貫的服務精神，隨時為您提供最佳服務，在您使用前務請詳閱本說明書，並依正確方法使用，閱讀完畢後請妥為保管，以備日後使用參考。

商品保證書

機型：SA-HQ10

購買日期： 年 月 日

顧客	姓名	電話：
	地址	
經銷商		

- 一.上列保證書應確實填寫，並蓋有經銷商店章始為有效。
- 二.免費服務年限為一年，自購買日起一年內，在正常使用下，如發生故障，則免費維修，但人為或天災地變或蟲害，不在此限。(如需服務換修零件，則按本公司服務規定，收取維修費)。
- 三.收費服務年限為兩年，收費服務兩年內，如需維修則按本公司服務規定，收取維修費。
- 四.自然耗材不在保固範圍內(例：電池、充電電池、天線、磁頭、雷射頭、耳機、遙控器、信號線、燈泡、刀具組、濾網、線材與隨機附贈之軟體及其他配件…等)。
- 五.本保證書遺失恕不補發，但如需服務，則依出廠日期，計算保證年度。
- 六.本商品無外修服務，如有另行約定則外出檢修費，依本公司規定收取；若發生故障請送回原購買經銷商或親洽本公司所屬營業所。
- 七.本商品維修範圍僅於“台、澎、金、馬”(需付擔一趟郵資)，其餘地區請自付來回郵資。
- 八.MP3、音響…等產品送修時，內存的資料(數位、類比)有可能流失，建議送修前請先行備份，若有資料遺失之情形，本公司將不負任何賠償責任，郵寄維修視同同意本條款。
- 九.本商品使用於營利商業用時，其保證期限按保證書所載期限減半保固。
- 十.任何商品會因為科技的不斷追求創新，推陳出新過程中不排除商品原始設備的硬體規格，無法滿足屆時的雲端技術、軟體搭配支援與最低硬體基本需求時，商品原始設備將自動停止雲端後台服務使用!本公司商品硬體保固一年，仍會不斷推出新相關類型商品，再歡迎繼續購買使用。

宣告：

說明書經仔細檢查及檢對，但仍不排除文字拼寫及技術錯誤之可能，此種錯誤或疏漏將於新版予以修正。本手冊之全部內容，本公司享有隨時修改之權利，且不另行通知。

委製商

旺德電通股份有限公司

新北市五股區五工三路116巷6號

服務專線:(02)8990-4440

E-mail:service1@wonder.tw

進口商:百佳諾國際貿易有限公司

地址:桃園市大園區青昇路一段90號

電話:(03)381-0536